

# Brake Caliper DH 030 PFM

pneumatically activated – spring released



Features	Code
Brake Caliper	D
Mounting to the machine at right angles to the brake disc	H
Frame size 030	030
Pneumatically activated	P
Spring released	F
Manual adjustment to accommodate friction block wear	M
Thrusters 635 or 655 are available	635 655
Thruster mounted right or left available	R L
Thickness of brake disc 12,5 mm or 25 mm	12 25

### Example for ordering

Brake Caliper DH 030 PFM, thruster 635, thruster mounted right, thickness of brake disc 12,5 mm:

DH 030 PFM - 635 R - 12

## Technical Data

### Brake Caliper DH 030 PFM - 635

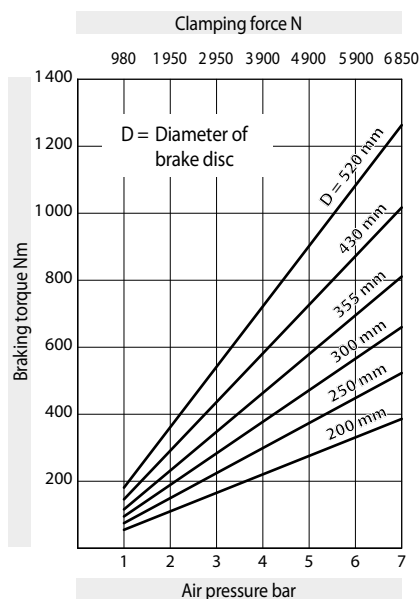

The braking torques shown in the diagram are based on a theoretical friction coefficient of 0,4.

Air pressure: max. 7 bar

Air volume: max. 175 cm<sup>3</sup> per activation

Weight: 7,7 kg

### Brake Caliper DH 030 PFM - 655

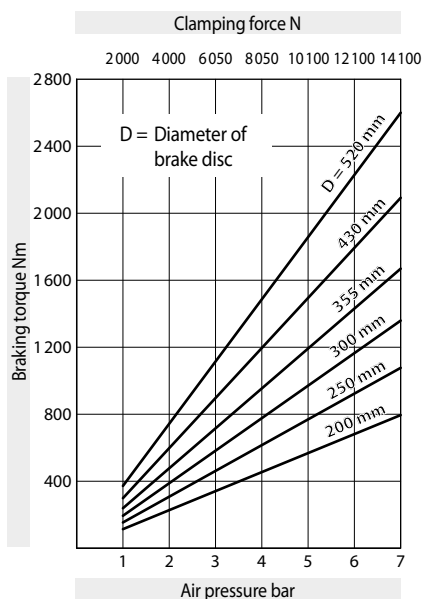

The braking torques shown in the diagram are based on a theoretical friction coefficient of 0,4.

Air pressure: max. 7 bar

Air volume: max. 740 cm<sup>3</sup> per activation

Weight: 10,9 kg

# Brake Caliper DH 030 PFM

pneumatically activated – spring released

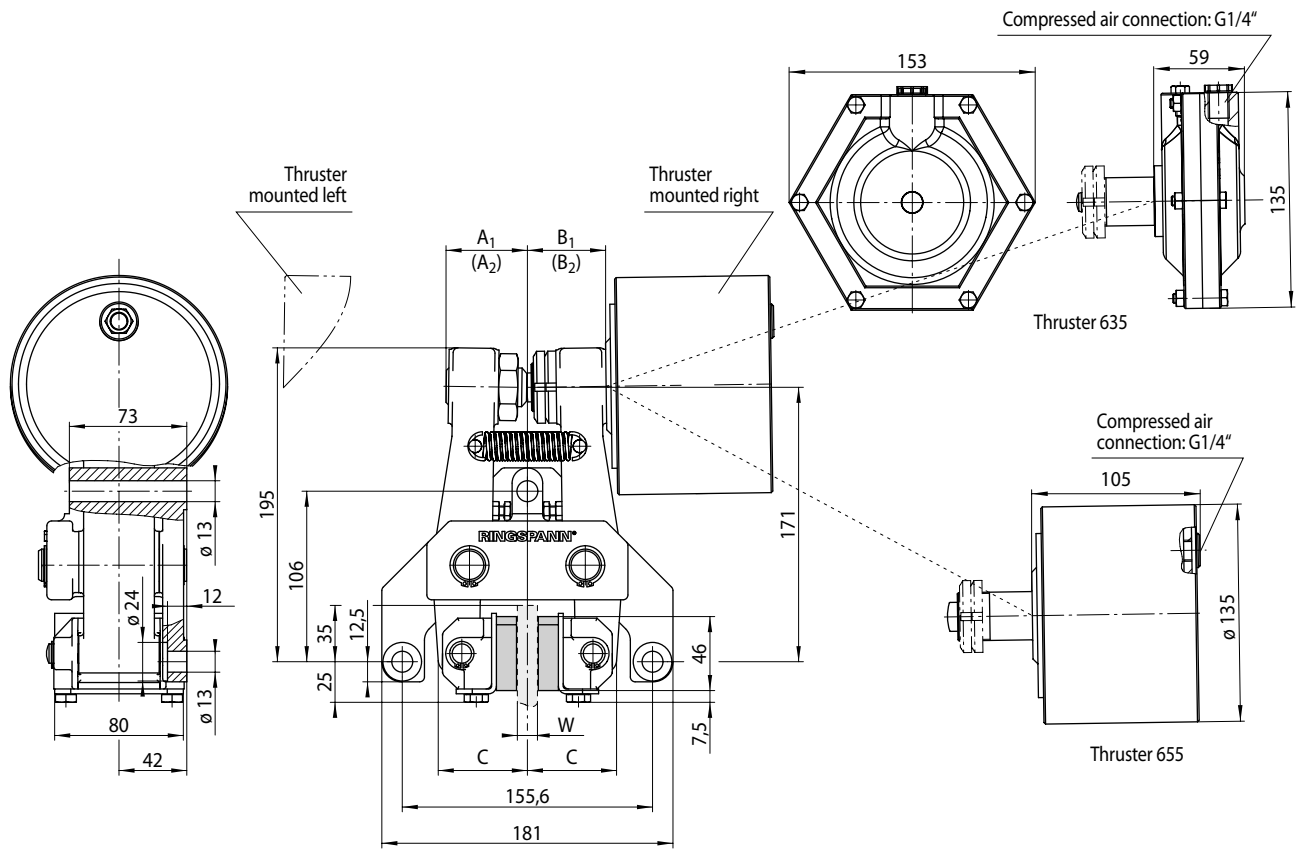

Thickness of brake disc W mm	A <sub>1</sub> mm	(A <sub>2</sub> ) mm	B <sub>1</sub> mm	(B <sub>2</sub> ) mm	C mm
12,5	54	(69)	49	(66)	55
25	60	(76)	56	(73)	62

Values in brackets resulting with maximum friction block wear.