

Brake Caliper DH 035 FPA

spring activated – pneumatically released

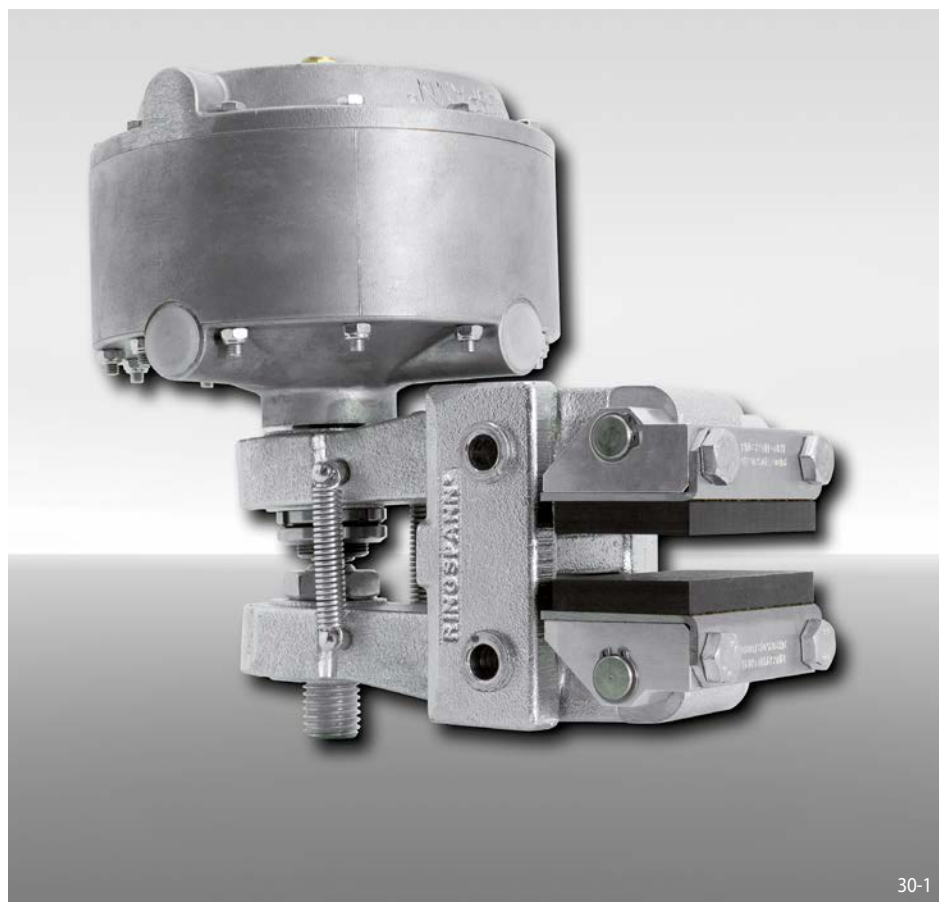

Features	Code
Brake Caliper	D
Mounting to the machine at right angles to the brake disc	H
Frame size 035	035
Spring activated	F
Pneumatically released	P
Automatic adjustment to accommodate friction block wear	A
Thrusters 065, 085, 095, 115 or 125 are available	065 to 125
Thruster mounted right or left available	R L
Thickness of brake disc 12,5 mm, 25 mm, 30 mm or 40 mm	12 to 40

Example for ordering

Brake Caliper DH 035 FPA, thruster 095, thruster mounted right, thickness of brake disc 12,5 mm:

Technical Data

DH 035 FPA - 095 R - 12

	Brake Caliper DH 035 FPA				
	with thruster 065	with thruster 085	with thruster 095	with thruster 115	with thruster 125
Brake disc diameter	Braking torque	Braking torque	Braking torque	Braking torque	Braking torque
mm	Nm	Nm	Nm	Nm	Nm
300	400	230	830	1350	1750
355	500	290	1050	1700	2150
430	630	360	1300	2100	2700
520	780	450	1600	2650	3350
630	970	560	2000	3250	4150
710	1100	640	2300	3750	4750
800	1250	730	2600	4250	5450
Clamping force	4300 N	2500 N	8900 N	14500 N	18500 N
Air pressure	min. 5 bar max. 8 bar	min. 1,7 bar max. 8 bar	min. 5 bar max. 8 bar	min. 5 bar max. 8 bar	min. 6,5 bar max. 8 bar
Air volume per activation	max. 72 cm ³	max. 140 cm ³	max. 140 cm ³	max. 460 cm ³	max. 460 cm ³
Weight	10,9 kg	13,3 kg	13,3 kg	14,9 kg	14,9 kg

The braking torques shown in the table are based on a theoretical friction coefficient of 0,4.

Brake Caliper DH 035 FPA

spring activated – pneumatically released

