

Brake Caliper DT 315 FEA ... ST

spring activated – electrohydraulically released
 Drum Brake according to DIN 15 435



Figure shows product with full equipment

174-1

Features	Code
Brake Caliper	D
Drum Brake	T
Frame size 315	315
Spring activated	F
Electrohydraulically released	E
Automatic adjustment to accommodate friction block wear	A
Thrusters 451, 452, 453 or 455 are available	451 to 455
Material: steel	ST

Example for ordering

Brake Caliper DT 315 FEA, thruster 453, material: steel

DT 315 FEA - 453 - ST

Technical Data

	Brake Caliper DT 315 FEA ... ST			
	with thruster 451	with thruster 452	with thruster 453	with thruster 455
Brake drum diameter	Braking torque	Braking torque	Braking torque	Braking torque
mm	Nm	Nm	Nm	Nm
315	350	480	950	1800
Clamping force	2800 N	3800 N	7500 N	14300 N
Braking torque adjustable	20 - 100%	20 - 100%	20 - 100%	20 - 100%
Nominal power	130 W	180 W	240 W	370 W
Oil volume	1,4 l	2,5 l	3,5 l	4,5 l
Voltage	230/400 V	230/400 V	230/400 V	230/400 V
Weight	56 kg	61 kg	63 kg	69 kg

The braking torques shown in the table are based on a theoretical friction coefficient of 0,4.

Brake Caliper DT 315 FEA ... ST

spring activated – electrohydraulically released
 Drum Brake according to DIN 15 435

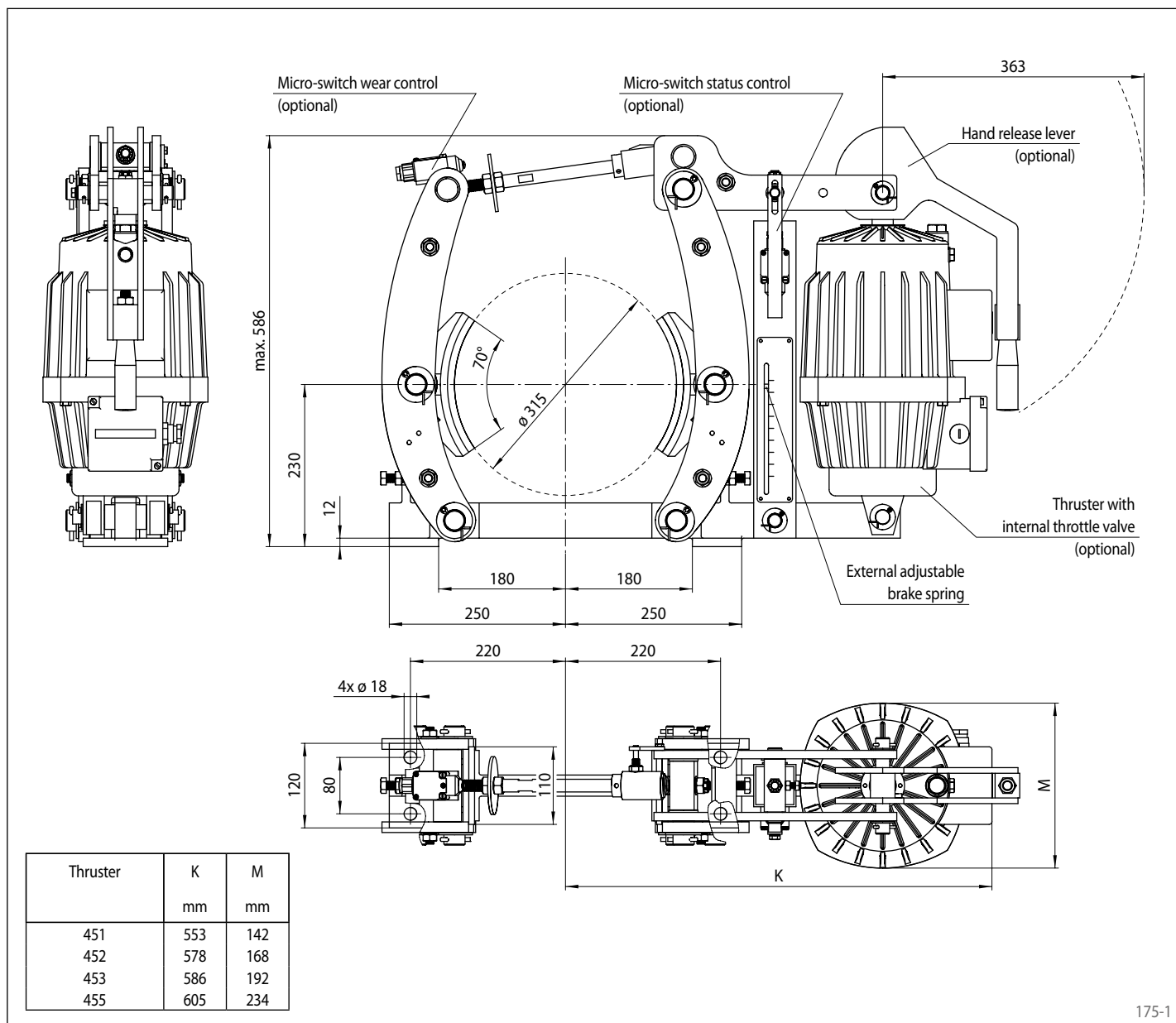

175-1

Options

- Micro-switch wear control
- Micro-switch status control
- Hand release lever
- Thruster with internal throttle valve
- Thruster in heat resistant design
- Corrosion protected design
- Wider brake shoes and brake drums