

Brake Caliper DT 400 FEA ... NC

spring activated – electrohydraulically released
 Drum Brake according to DIN 15 435



Figure shows product with full equipment

178-1

Features	Code
Brake Caliper	D
Drum Brake	T
Frame size 400	400
Spring activated	F
Electrohydraulically released	E
Automatic adjustment to accommodate friction block wear	A
Thrusters 452, 453, 454 or 455 are available	452 to 455
Material: cast	NC

Example for ordering

Brake Caliper DT 400 FEA, thruster 453, material: cast

DT 400 FEA - 453 - NC

Technical Data

	Brake Caliper DT 400 FEA ... NC			
	with thruster 452	with thruster 453	with thruster 454	with thruster 455
Brake drum diameter	Braking torque	Braking torque	Braking torque	Braking torque
mm	Nm	Nm	Nm	Nm
400	525	1040	1300	2075
Clamping force	3300 N	6500 N	8100 N	13000 N
Braking torque adjustable (optional)	20 - 100%	20 - 100%	20 - 100%	20 - 100%
Nominal power	180 W	240 W	280 W	370 W
Oil volume	2,5 l	3,5 l	3,5 l	4,5 l
Voltage	230/400 V	230/400 V	230/400 V	230/400 V
Weight	80 kg	82 kg	82 kg	88 kg

The braking torques shown in the table are based on a theoretical friction coefficient of 0,4.

Brake Caliper DT 400 FEA ... NC

spring activated – electrohydraulically released
Drum Brake according to DIN 15 435

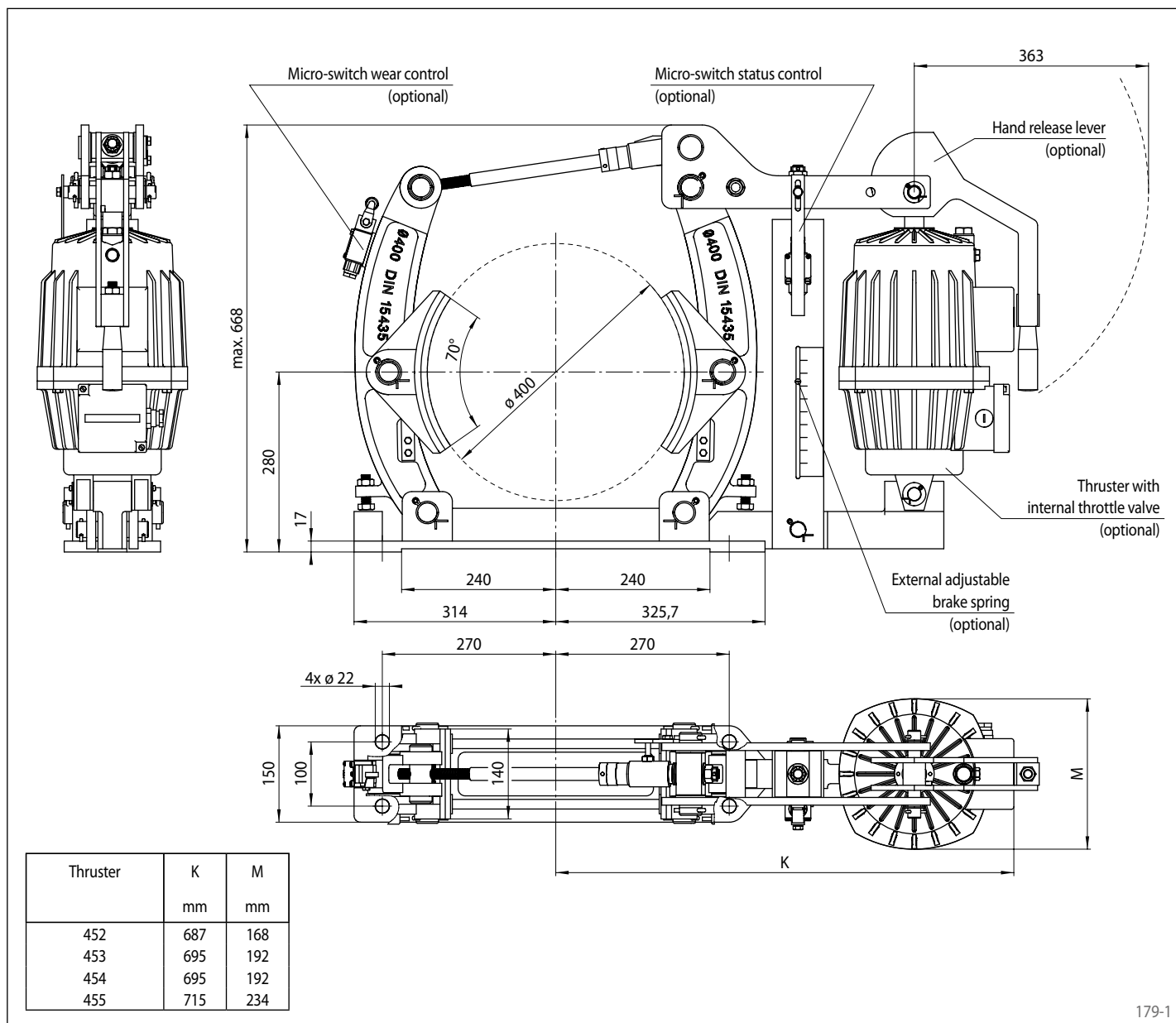

179-1

Options

- External adjustable brake spring
- Micro-switch wear control
- Micro-switch status control
- Hand release lever
- Thruster with internal throttle valve
- Thruster in heat resistant design
- Corrosion protected design
- Wider brake shoes and brake drums