

Brake Caliper DT 500 FEM ... NC

spring activated – electrohydraulically released
 Drum Brake according to DIN 15 435



Figure shows product with full equipment

182-1

Features	Code
Brake Caliper	D
Drum Brake	T
Frame size 500	500
Spring activated	F
Electrohydraulically released	E
Manual adjustment to accommodate friction block wear	M
Thrusters 455 or 456 are available	455 456
Material: cast	NC

Example for ordering

Brake Caliper DT 500 FEM, thruster 456, material: cast

DT 500 FEM - 456 - NC

Technical Data

	Brake Caliper DT 500 FEM ... NC	
	with thruster 455	with thruster 456
Brake drum diameter	Braking torque	Braking torque
mm	Nm	Nm
500	2500	4170
Clamping force	12500 N	20800 N
Braking torque adjustable (optional)	20 - 100%	20 - 100%
Nominal power	370 W	590 W
Oil volume	4,5 l	11 l
Voltage	230/400 V	230/400 V
Weight	130 kg	156 kg

The braking torques shown in the table are based on a theoretical friction coefficient of 0,4.

Brake Caliper DT 500 FEM ... NC

spring activated – electrohydraulically released
 Drum Brake according to DIN 15 435

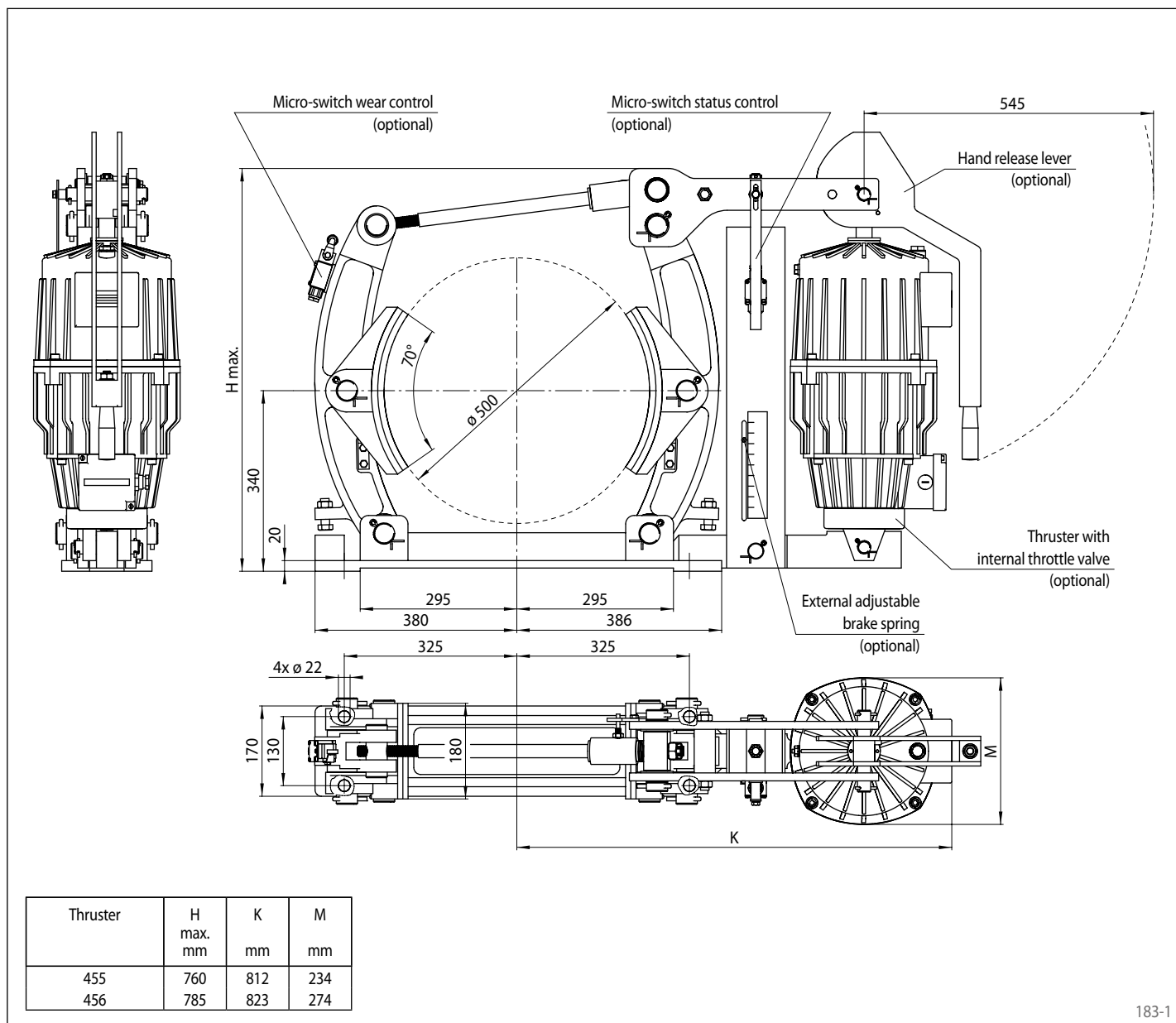

183-1

Options

- External adjustable brake spring
- Micro-switch wear control
- Micro-switch status control
- Hand release lever
- Thruster with internal throttle valve
- Thruster in heat resistant design
- Corrosion protected design
- Wider brake shoes and brake drums