

Brake Caliper DV 020 MSM

manually activated – manually released
with hand wheel



Features	Code
Brake Caliper	D
Mounting to the machine parallel to the brake disc	V
Frame size 020	020
Manually activated	M
Manually released	S
Manual adjustment to accommodate friction block wear	M
Hand wheel 720	720
Hand wheel mounted right or left available	R L
Thickness of brake disc 12,5 mm	12

Example for ordering

Brake Caliper DV 020 MSM, hand wheel 720, hand wheel mounted right, thickness of brake disc 12,5 mm:

DV 020 MSM - 720 R - 12

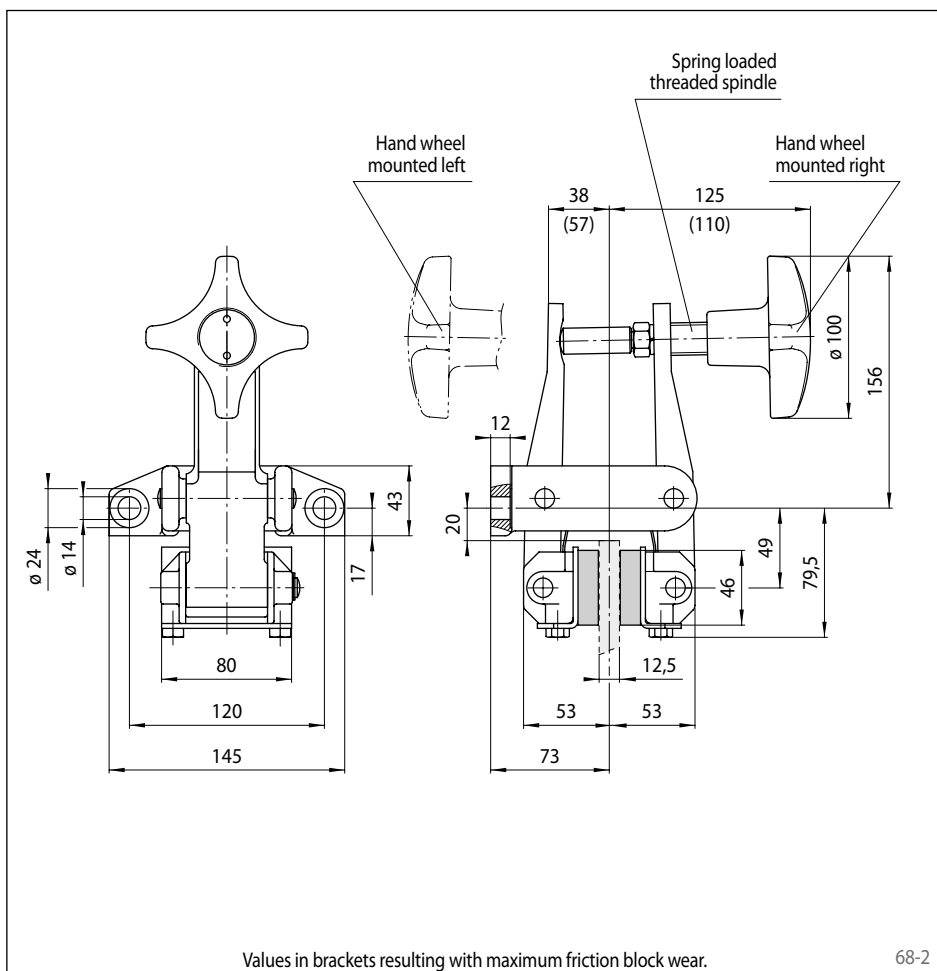

Technical Data

Brake Caliper DV 020 MSM with hand wheel 720	
Brake disc diameter	Braking torque
mm	Nm
200	160
250	215
300	270
355	335
430	420
520	520
Clamping force	2800 N
Weight	4,8 kg

The braking torques shown in the diagram are based on a theoretical friction coefficient of 0,4. The maximum braking torques are based on an operating torque of 7,7 Nm at the hand wheel.

A spring loaded threaded spindle compensates for wear of the friction block during the braking action.