

# Brake Caliper DV 020 PFK

pneumatically activated – spring released



52-1

## Features

Features	Code
Brake Caliper	D
Mounting to the machine parallel to the brake disc	V
Frame size 020	020
Pneumatically activated	P
Spring released	F
No adjustment to accommodate friction block wear	K
Thruster 630	630
Thruster mounted in central position	M
Thickness of brake disc 12,5 mm	12

## Example for ordering

Brake Caliper DV 020 PFK, thruster 630, thruster mounted in central position, thickness of brake disc 12,5 mm:

DV 020 PFK - 630 M - 12

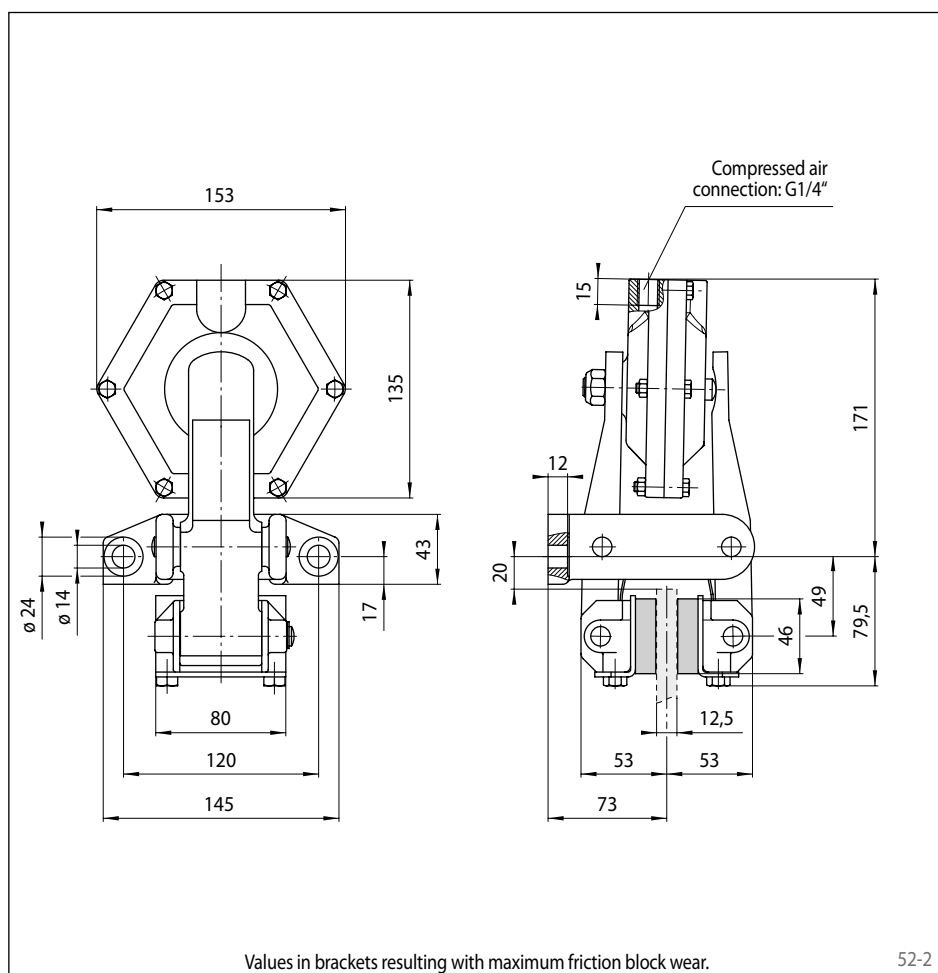

52-2

## Technical Data

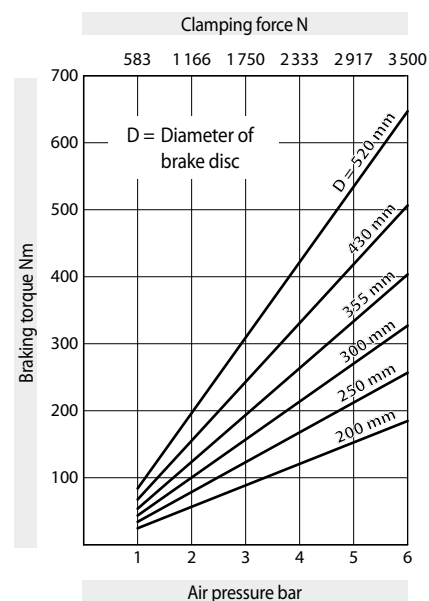

The braking torques shown in the diagram are based on a theoretical friction coefficient of 0,4.

Air pressure: max. 6 bar

Air volume: max. 120 cm<sup>3</sup> per activation

Weight: 4,8 kg