

Brake Caliper HW 215 FHM

spring activated – hydraulically released

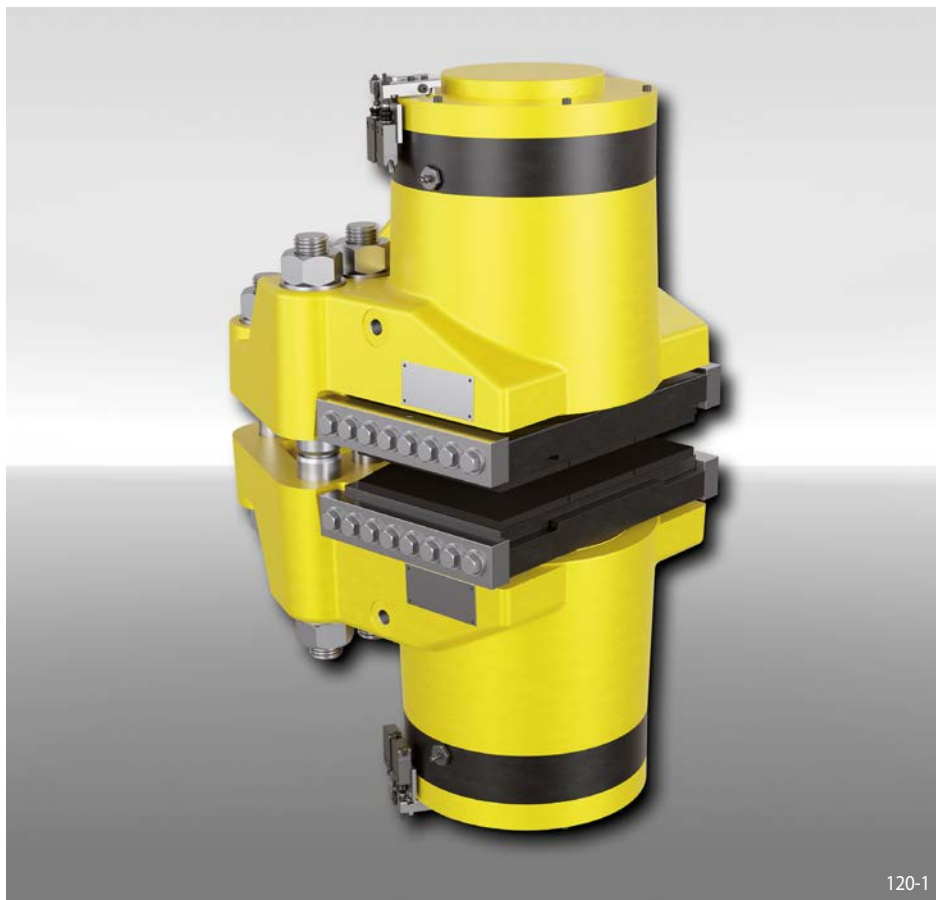

Features	Code
Brake Caliper	H
Standard	W
Frame size 215	215
Spring activated	F
Hydraulically released	H
Manual adjustment to accommodate friction block wear	M
Max. clamping force 555 kN	555

Example for ordering

Brake Caliper HW 215 FHM, max. clamping force 555 kN:

HW 215 FHM-555

Technical Data

Brake disc diameter mm	Braking torque Nm
1 000	164 400
1 250	220 000
1 600	297 800
2 000	386 700
3 000	608 900
3 500	720 000
4 000	831 100
Clamping force	555 kN
Oil pressure	min. 230 bar max. 250 bar
Oil volume	max. 270 cm ³
Thickness of brake disc W	min. 30 mm
Weight	650 kg

The braking torques shown in the table are based on a theoretical friction coefficient of 0,4.

Working conditions

- Ambient temperature: -20 °C / +60 °C
- Air humidity: <90%

Monitoring switch

- 240 VAC 1.5 A; 250 VDC 0.1 A
- Cable 5 x 0.75 mm², length 2 m, outer diameter 7.5 mm
- Protection type IP67

Options

- Friction pads with wear indicator cables or sintered friction linings (for high temperatures)
- Corrosion-protected version
- Low temperature version
- Offshore certifications
- ATEX certifications for hazardous areas

Notes

- Includes two pairs of ø 55_{g6} shear pins
- Eyebolts included
- Fastening:
6 screws M42, class 10.9 with tightening torque 4 100 Nm ±5% μ 0.10 (not supplied)

Brake Caliper HW 215 FHM

spring activated – hydraulically released

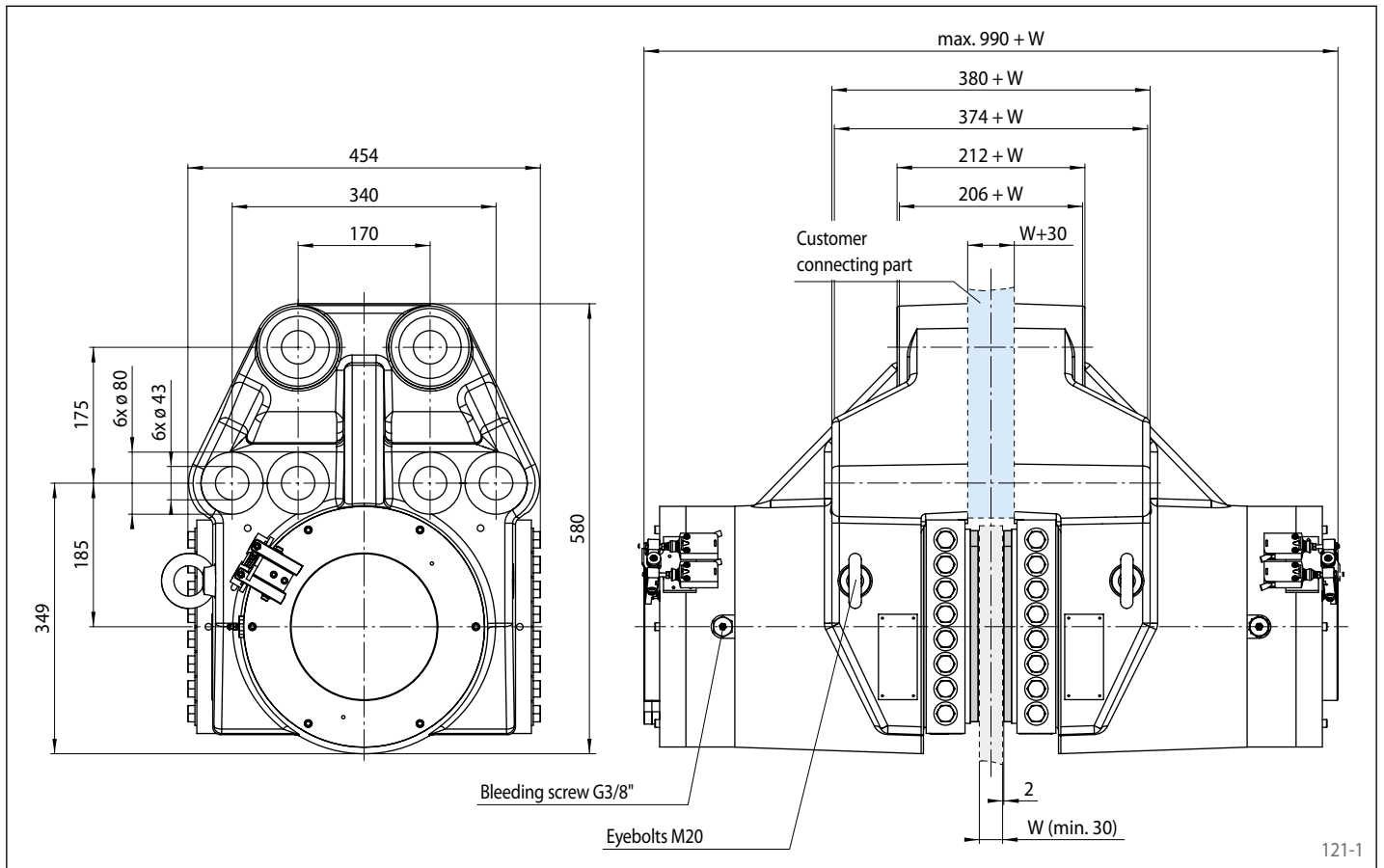

121-1

Mounting

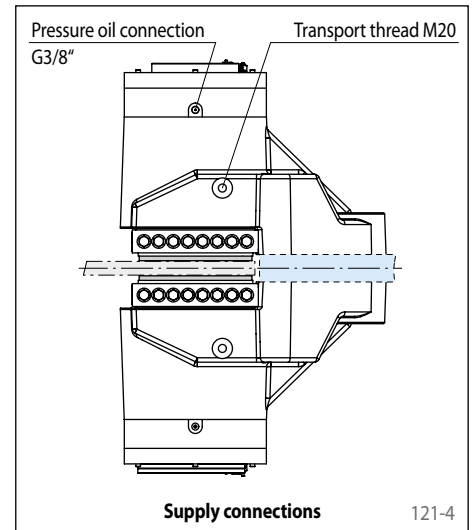
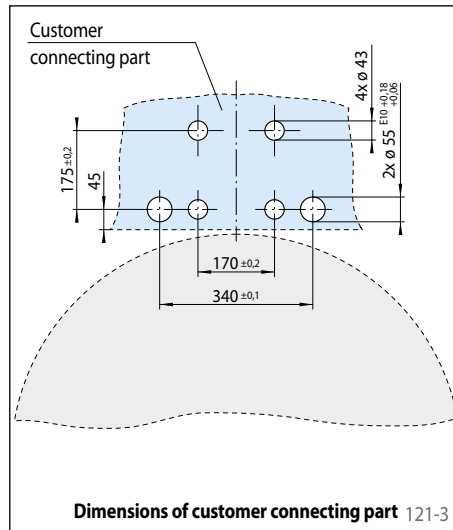
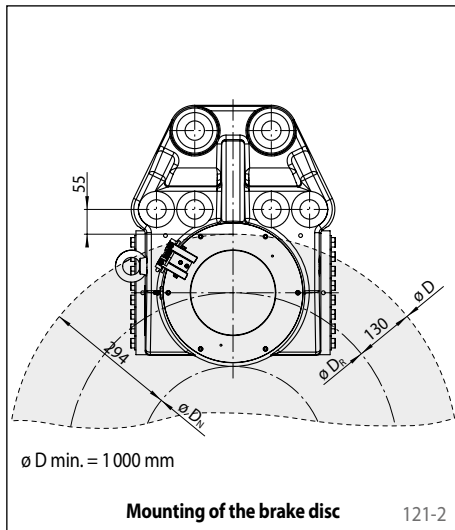

Calculation of the friction diameter

$$D_R = D - 260 \text{ mm}$$

Calculation of the hub diameter

$$D_N = D - 588 \text{ mm}$$

Calculation of the braking torque

$$M_B = F_K \cdot D_R \cdot \mu$$

Formula symbols

D = Outer diameter brake disc [mm]

D_N = Hub diameter [mm]

D_R = Friction diameter [mm]

F_K = Clamping force [N]

M_B = Braking torque [Nm]

μ = Friction coefficient