

# Clamping Unit KE ... FHK

spring activated – hydraulically released

**RINGSPANN®**



Features	Code
Clamping Unit	K
Standard	E
Sizes 32, 37, 42, 47, 57, 70, 90, 105, 140 or 160 are available	032 to 160
Spring activated	F
Hydraulically released	H
No wear adjustment	K
For piston rod diameter from 12 mm to 115 mm	012 to 115

## Example for ordering

Clamping Unit KE 037 FHK with piston rod diameter 16 mm:

KE 037 FHK - 016

## Description

The Clamping Unit KE ... FHK clamps and holds hydraulic cylinder drawbars with a calculated clamping force in both directions of move-

ment. The clamping force is generated via built-in disc springs. The Clamping Unit is released by hydraulic pressure.

The units are fitted to cylinders and other machine parts with a connecting flange by the customer.

## Operation

During the working stroke of the hydraulic cylinder, pressure is exerted onto the Clamping Unit. Through this pressure the disc springs are compressed via the piston. In this position, the clamping discs are free of axial tension and thus allow the piston rod to move freely.

When the pressure on the Clamping Unit is removed, the force of the springs work fully onto the piston and therefore also on to the disc pack. The clamping discs translate the axial spring pressure into a radial force applied to the slotted clamping sleeve that is equal to at least five times the axial pressure. The clamping

sleeve transmits the radial clamping forces to the piston rod, thereby holding the piston rod firmly in place.

Each time the pressure falls - even when this was not planned - the Clamping Unit will respond immediately.

## Application

The Clamping Unit secures the piston rod with precision against unintentional axial movements.

For example, on machines with cylinders or linear motors a certain position can be driven in one continuous movement. With the Clamping Unit this position can then be held mechanically with accuracy.

The accuracy of the safety Clamping Unit is independent of the size and the direction of the force on the piston rod up to the maxi-

mum holding force indicated. No movement of the piston rod is required for the holding force to become effective; the clamping force is effective immediately and does not depend on outside forces. If it is necessary to brake the movement of the piston rod, the Clamping Unit would, when pressure falls, produce virtually without delay a constant friction force independent of time. The slowing down of the piston rod is therefore even and protects the decelerated components of the installation.

## Features

- For continuous piston rod clamping
- Spring activated, hydraulically released
- Holding forces transmissible in both directions of movement
- No application of force (lifting) to the piston rod required for release

# Clamping Unit KE ... FHK

spring activated – hydraulically released

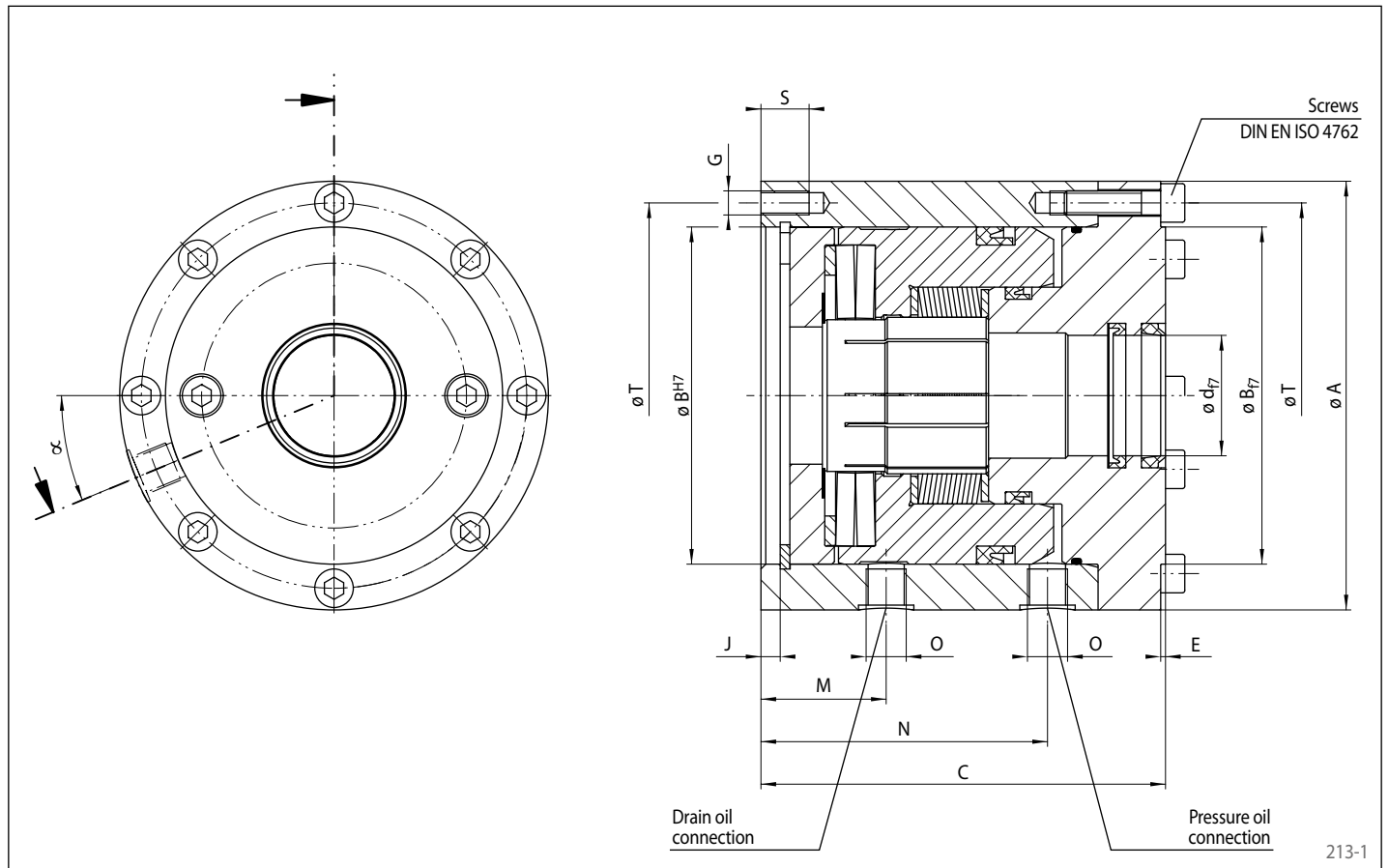

213-1

Size	Piston rod- ø d <sup>1)</sup> mm	Holding force F <sub>H</sub> <sup>2)</sup> N	A mm	B mm	C mm	E mm	G	J mm	M mm	N mm	O	S mm	T mm	X <sup>3)</sup>	Necess. release press bar	Max. perm. press. bar	Oil vol. per stroke cm <sup>3</sup>	α Degree	Weight kg
32	<b>12</b>	2 500	72	48	76	2	M 5	5	26	54	R1/8"	9	60	4	57	120	1	22,5	2,1
37	<b>14</b>	5 000	85	60	88	2	M 6	6	31	64	R1/8"	11	72	4	68	120	2	22,5	3,4
	16																		
42	<b>20</b> 22	8 000	100	68	100	2	M 6	6	34	72	R1/8"	11	85	4	82	120	2	22,5	5,3
47	<b>25</b> 28	12 500	110	80	115	2	M 6	7	42	85	R1/8"	15	92	6	84	120	3	22,5	7,3
57	(30) <b>32</b> 34	19 000	130	95	130	2	M 8	7	48	96	R1/4"	16	112	6	88	120	5	22,5	11,5
	36																		
70	<b>40</b> 45	30 000	150	116	148	3	M 8	4	52	108	R1/4"	16	132	8	102	120	6	22,5	17,2
90	<b>50</b> (55) 56	48 000	178	140	168	3	M 10	8	52	119	R3/8"	20	160	8	108	160	13	22,5	27,2
105	<b>60</b> <b>63</b> 70	68 000	210	168	185	3	M 12	10	60	133	R3/8"	22	190	8	122	160	17	22,5	41,2
140	<b>80</b> (85) 90	120 000	273	220	230	3	M 14	12	75	172	R3/8"	25	250	12	115	160	39	15	86,9
160	<b>100</b> 110 (115)	200 000	330	270	270	5	M 18	16	90	200	R3/8"	38	300	12	110	160	64	15	148,2

<sup>1)</sup> Diameter printed in bold to be preferred. Diameter line without ( ) corresponds to DIN 24334.

<sup>2)</sup> Please note recommendations on page 217.

<sup>3)</sup> Number of tapped holes G or screws DIN EN ISO 4762 on pitch øT.