

Clamping Unit KE ... FPK

spring activated – pneumatically released



Features

Clamping Unit

Code

K

Standard

E

Sizes 40, 50, 63, 80 or 100 are available

040
to
100

Spring activated

F

Pneumatically released

P

No wear adjustment

K

Example for ordering

Clamping Unit KE 040 FPK:

↓
KE 040 FPK

Description

The Clamping Unit KE ... FPK clamps and holds pneumatic cylinder piston rods with a calculated clamping force in both directions

of movement. The clamping force is applied by disc springs. Clamping force is released by pneumatic pressure.

The Clamping Units can be bolted directly to any cylinder of the ISO series or attached to other machine components with a connection flange provided by the customer.

Operation

Pneumatic pressure is applied to the Clamping Unit during the working stroke of the pneumatic cylinder. This pressure is transmitted by the piston via the lever spring to the mount and presses the disc springs together. The lever spring translates the pressure into a clamping force. In this position, the clamping discs are free of axial tension and thus allow the piston rod to move freely.

When the pressure on the Clamping Unit is removed, the force of the springs work fully onto the piston and therefore also on to the disc pack. The clamping discs translate the axial spring pressure into a radial force applied to the slotted clamping sleeve that is equal to at least five times the axial pressure. The clamping sleeve transmits the radial clamping forces to the piston rod, thereby holding the piston rod firmly in place.

Each time the pressure falls - even when this was not planned - the Clamping Unit will respond immediately.

Application

The Clamping Unit secures the piston rod with precision against unintentional axial movements.

For example, on machines with cylinders or linear motors a certain position can be driven in one continuous movement. With the Clamping Unit this position can then be held mechanically with accuracy.

The accuracy of the safety Clamping Unit is independent of the size and the direction of the force on the piston rod up to the maximum holding force indicated. No movement of the piston rod is required for the holding force to become effective; the clamping force is effective immediately and does not depend on outside forces.

Clamping Unit KE ... FPK

spring activated – pneumatically released

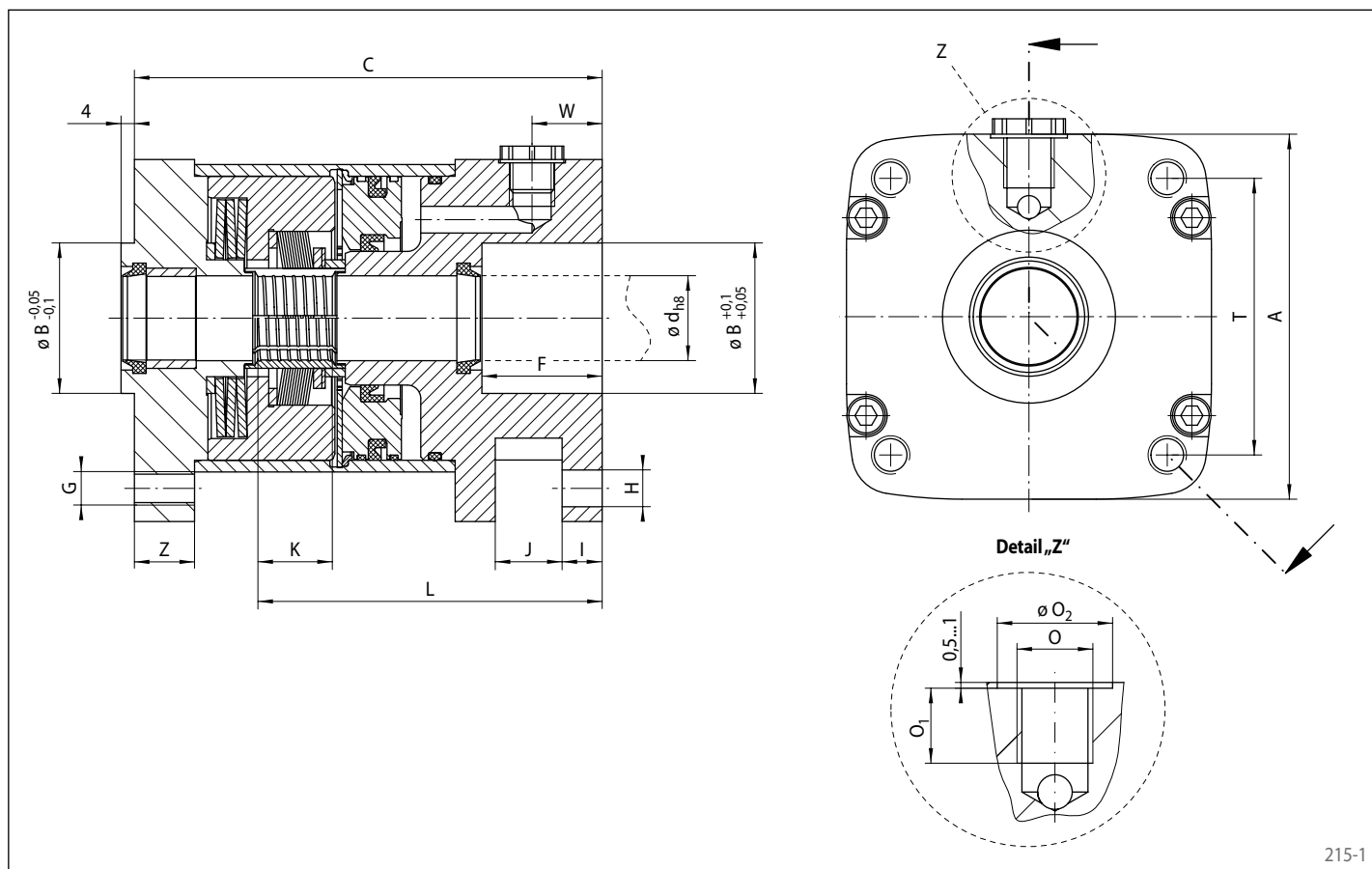

215-1

Size	Piston rod- ø d mm	Holding force F_H ¹⁾ N	A mm	B mm	C mm	F mm	G	H mm	I mm	J mm	O	O ₁ mm	O ₂ mm	T mm	W mm	Z mm	Air volume per activa- tion cm ³	Weight kg
40	16	1 000	70	35	95	24	M6	6,6	6	14	G1/8	10,5	16	38	15,5	13	5,5	1,1
50	20	1 600	75	40	112	30	M8	9	8	16	G1/4	12,5	20	46,5	22,9	13	13,5	1,5
63	20	2 500	95	45	120	30	M8	9	8	16	G1/4	14	20	56,5	15,0	12	27	3,2
80	25	4 000	95	45	140	36	M10	11	12	20	G1/4	14	20	72	21,0	18	27	3,5
100	25	6 300	120	55	150	40	M10	11	12	20	G1/4	14	20	89	21,0	19	59	5,8

¹⁾ Please note recommendations on page 217.

Features

- For continuous piston rod clamping
- Spring activated, pneumatically released
- Connection dimensions compatible with pneumatic cylinders according to ISO
- Direct mounting on pneumatic cylinders
- Holding forces transmissible in both directions of movement
- No application of force (lifting) to the piston rod required for release

Release pressure

The release pressure of the spring activated pneumatically released Clamping Unit KE ... FPK is min. 5 bar and max. 8 bar.