

Thrusters TH with Impeller

for electrohydraulic brakes



Issue 04/2026 · Technical details subject to change without notice.

E09.062e



Thrusters TH with Impeller

for electrohydraulic brakes



Features	Code
Thruster	T
Design	H
Lifting forces of 220 N, 300 N, 600 N, 750 N, 1 200 N, 1 500 N, 2 000 N or 3 000 N are available	022 to 300
Total stroke of 50 mm, 60 mm or 120 mm are available	05 06 12
Installation dimension h1 (see page 3)	286 to 705
Options (see page 4)	...

Example for ordering

Thruster TH, lifting force 2000 N, total stroke 60 mm, installation dimension h1 645 mm, with manual hand release and increased corrosion protection:

TH 200 - 06 - 645 - LS - M

Design and function

The electrohydraulic thruster combines all the basic elements of a hydraulic system in a coaxial unit: an electric motor, a hydraulic pump and a cylinder with a piston. It is designed to exert a constant linear force for a given stroke.

The centrifugal pump impeller coupled to the motor shaft builds up hydraulic pressure under the piston, which causes an upward movement against the external (brake-side) spring. When the motor is switched off, the piston is reset by the external (brake-side) spring.

The hydraulic force is almost independent of the piston position of the cylinder. With a lower load, the stroke movement is faster and the downward movement slower.

Advantages

- The hydraulic force of the thruster is independent of the position of the piston rod.
- The thruster cannot be overloaded, even if an external force acts on the piston rod that is greater than the thrust of the thruster.

General technical data

Motor	2-pole Three-phase squirrel cage
Insulation level	F
Voltage	230 / 400 VAC 3~
Supply frequency	50 Hz
Duty factor	100%
Max. number of actuation	2 000/h
Insulation	IP56
Oil filling	IP Hydrus Oil 10
Mounting position	vertical with piston rod upwards
Permissible ambient temperature	-20 °C - +45 °C

Code and description of possible options

Options	Code
<ul style="list-style-type: none"> • For temperatures down to -30 °C Filling with a special oil 	(A)
<ul style="list-style-type: none"> • For temperatures down to -40 °C With an electric heating rod for 230 VAC 	(AA)
<ul style="list-style-type: none"> • For temperatures up to +70 °C With special seals 	(W)
<ul style="list-style-type: none"> • For temperatures briefly up to +100 °C With special seals, pressure relief valve, special paint and special oil 	(HR)
<ul style="list-style-type: none"> • Lowering valve Slows down the lowering of the piston rod 	(SV)
<ul style="list-style-type: none"> • Non-standard voltage & frequency For use with non-standard voltages or frequencies 	(Vf)
<ul style="list-style-type: none"> • Built-in spring C-spring creates setting force of the thruster (or clamping force when thruster is installed in a brake) 	(C)
<ul style="list-style-type: none"> • External attenuation spring Additional spring on the piston rod for better adjustability 	(R)
<ul style="list-style-type: none"> • Rubber hood To protect the piston rod 	(Cap)
<ul style="list-style-type: none"> • Design in insulation IP65 Additional seal on the terminal box 	(IP65)
<ul style="list-style-type: none"> • With hand release lever To manually drive out the piston rod in a de-energised state (brake release) 	(LS)
<ul style="list-style-type: none"> • Horizontal application For horizontal operation, an additional component is required internally 	(hor)
<ul style="list-style-type: none"> • Terminal box turned 90° 	(T)
<ul style="list-style-type: none"> • Other colour than RAL 9005 	(Col)
<ul style="list-style-type: none"> • Version with increased corrosion protection 	(M)

External attenuation spring (R)

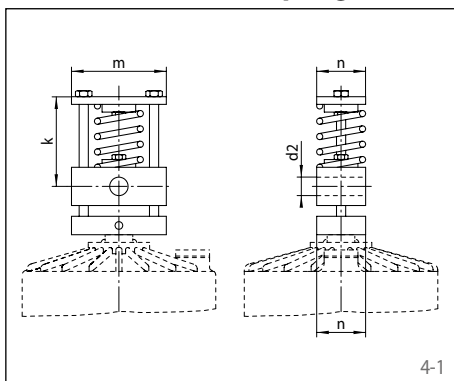

Rubber hood (Cap)

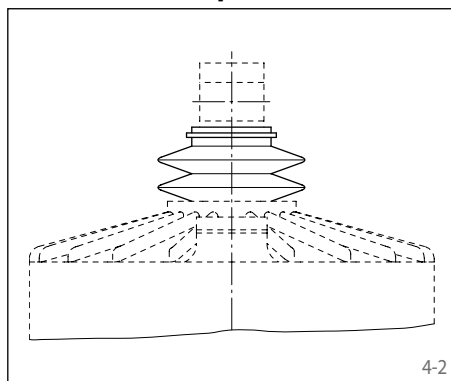

With hand release lever (LS)

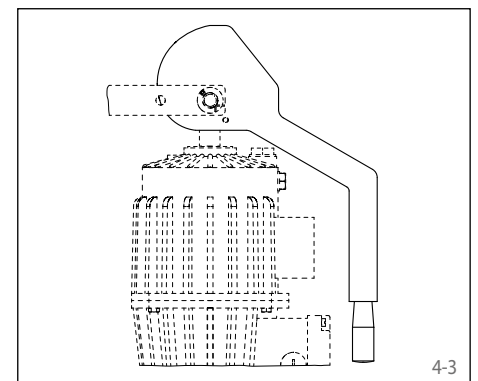

Please note:

The options can not be combined arbitrarily. If you need more options, please contact RINGSPANN.

Motor connection

- The three ends of the supply cable can be connected to the terminals in any order, since the fan operates independently of the direction of rotation of the motor.
- The thruster should be switched via a separate contractor. The direct parallel connection with e.g. the crane motor can delay the lowering time and thus the braking effect.
- The thrusters are insensitive to voltage fluctuations of up to $\pm 10\%$.
- Mounting points for an earthing cable are provided inside and outside the terminal box.
- The terminal box has a PG gland on each side for cable feedthrough.

Hydraulic oil

The thruster is delivered complete with oil filling IP Hydrus Oil 10.

Oils from other manufacturers with a viscosity of approx. $10 \text{ mm}^2/\text{s}$ at $+40^\circ\text{C}$ can also be used.

Examples:

- ESSO Spinesso 10
- Shell Tellus Oil 10
- CHEVRON Spindel Oil 10
- Aral Vitam GF 10
- etc.

Operating and ambient temperature

All thrusters are designed for continuous operation and for interval operation with up to 2000 operations/hour at ambient temperatures ranging from -20°C to $+45^\circ\text{C}$. At temperatures

of more than $+45^\circ\text{C}$ the oil becomes thinner; the hydraulic losses increase and the hydraulic forces decrease. At temperatures below -20°C the oil becomes denser and the piston move-

ments become slower. For these reasons, the thrusters must be filled with a suitable type of oil for extreme ambient temperatures.

Capacitor for fast downward movement

The lowering time of the piston rod can be reduced by using three capacitors connected in parallel. Typical applications are brakes for winches with a lifting speed of more than 8 m/min.

Recommended capacity values:

TH 022-05-286 / TH 030-05-380	3x10 μF
TH 060-05-406 / TH 075-05-406 / TH 120-06-450 / TH 120-12-515 / TH 150-06-450	3x20 μF
TH 200-06-645 / TH 300-06-645 / TH 200-12-705 / TH 300-12-705	3x50 μF

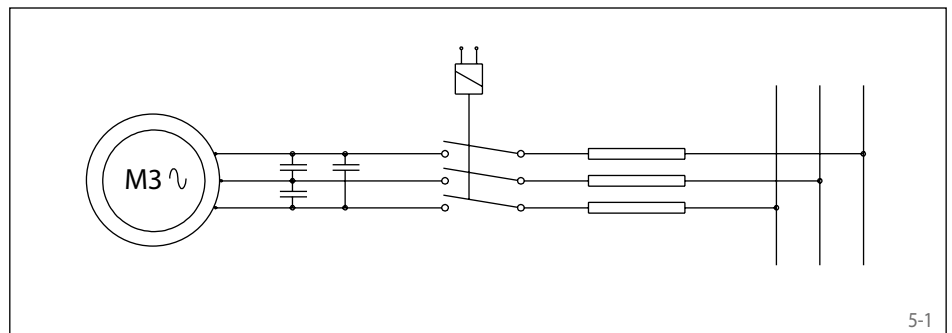

5-1

Germany

RINGSPANN GmbH

Schaberweg 30-38, 61348 Bad Homburg
Germany • +49 6172 275 0
info@ringspann.de • www.ringspann.de

RINGSPANN Kempf GmbH

Moorstraße 4, 36129 Gersfeld (Rhön), Germany
+49 6654 9611 0 • info@ringspann-kempf.de
www.ringspann-kempf.de

RINGSPANN StS GmbH

Hansaring 6, 63843 Niedernberg, Germany
+49 6028 40642 0 • info@ringspann-sts.de
www.ringspann-sts.de

RINGSPANN RCS GmbH

Hans-Mess-Straße 7, 61440 Oberursel, Germany
+49 6172 67 68 50
info@ringspann-rcs.de • www.ringspann-rcs.de

**Bosnia and Herzegovina, Serbia,
Croatia, Montenegro, Kosovo,
North Macedonia, Albania**

RINGSPANN Bosanska Krupa d.o.o.

Radnicka bb, 77240 Bosanska Krupa, Bosnia and
Herzegovina • +387 37 961 444
info@ringspann.ba • www.ringspann.ba

France

RINGSPANN France S.A.

23 rue Saint-Simon, 69009 Lyon, France
+33 4 7883 5901
info@ringspann.fr • www.ringspann.fr

Great Britain, Ireland

RINGSPANN (U.K.) LTD.

3, Napier Road, Bedford MK41 0QS, Great Britain
+44 1234 3425 11
info@ringspann.co.uk • www.ringspann.co.uk

Italy

RINGSPANN Italia S.r.l.

Via A.D. Sacharov, 13, 20812 Limbiate (MB), Italy
+39 02 93 57 12 97
info@ringspann.it • www.ringspann.it

Netherlands, Belgium, Luxembourg

RINGSPANN Benelux B.V.

Nieuwenkampsmaten 6 - 15, 7472 DE Goor,
Netherlands • +31 547 26 13 55
info@ringspann.nl • www.ringspann.nl

Austria, Czech Republic,

Hungary, Slovakia, Slovenia

RINGSPANN Austria GmbH

Triesterstraße 21, 2620 Neunkirchen, Austria
+43 26 35 624 46
info@ringspann.at • www.ringspann.at

Poland

Radius-Radpol Wiecheć Sp.J.
Ul. Pasjonatów 3, 62-070 Dąbrowa, Poland
+48 61 814 39 28 • info@radius-radpol.com.pl
www.radius-radpol.com.pl

Romania, Bulgaria, Moldova

S.C. Industrial Seals and Rolls S.R.L.
Str. Depozitelor, No. 29, 110078 Pitesti, Romania
+4 0751 22 82 28
mihai@isar.com.ro • www.isar.com.ro

Sweden, Finland, Denmark,

Norway, Baltic states

RINGSPANN Nordic AB

Industrigatan 10A, 619 33 Trosa, Sweden
+49 6172 275 170
info@ringspann.se • www.ringspann.se

Switzerland

RINGSPANN AG

Sumpfstrasse 7, P.O. Box, 6303 Zug,
Switzerland • +41 41 748 0900
info@ringspann.ch • www.ringspann.ch

Spain, Portugal

RINGSPANN IBERICA S.A.

C/Uzbina, 24-Nave E1, 01015 Vitoria, Spain
+34 945 22 77-50
info@ringspann.es • www.ringspann.es

**Turkey, Azerbaijan, Kazakhstan,
Kyrgyzstan, Tajikistan, Turkmenistan,
Uzbekistan**

RINGSPANN Turkey Güç Aktarım Sistemleri Ticaret Limited Şirketi

Fatih Sultan Mehmet Mah, Poligon Cad. Buyaka 2
Sitesi 3 Blok No: 8 İç Kapı No: 1, 34771 Ümraniye /
Istanbul, Turkey • +90 532 165 7760
info@ringspann.tr • www.ringspann.tr

Ukraine

"START-UP" LLC.
Saltivske Hwy, 43, letter G-3, office 101,
Kharkiv 61038, Ukraine • +38 057 717 03 04
start-up@start-up.kh.ua • www.start-up.kh.ua

Asia

Australia, New Zealand

RINGSPANN Australia Pty Ltd

10 Network Drive, Carrum Downs Vic 3201,
Australia • +61 3 9069 0566
info@ringspann.com.au • www.ringspann.com.au

China, Taiwan

RINGSPANN Power Transmission (Tianjin) Co., Ltd.

No. 21 Gaoyan Rd., Binhai Science and Technology
Park, Binhai Hi-Tech Industrial, Development Area,
Tianjin, 300458, P.R. China • +86 22 5980 31 60
info.cn@ringspann.cn • www.ringspann.cn

India, Bangladesh, Nepal

RINGSPANN Power Transmission India Pvt. Ltd.

GAT No: 679/2/1, Village Kuruli, Taluka Khed, Chakan-
Alandi Road, Pune - 410501, Maharashtra, India
+91 21 35 67 75 00 • info@ringspann-india.com
www.ringspann-india.com

Singapore, ASEAN

RINGSPANN Singapore Pte. Ltd.

143 Cecil Street, #17-03 GB Building,
Singapore 069542 • +6012 589 8975
info@ringspann.sg • www.ringspann.sg

South Korea

RINGSPANN Korea Ltd.

33 Gojae-17 Ghil Dongnam-gu, 31187 Cheonan-si
Chungnam, South Korea • + 82 10 54961 368
info@ringspann.kr • www.ringspann.kr

America

Brazil

RINGSPANN do Brasil Ltda.

Rua Vereador Oclésio Antonio Rebutini, 480
CEP 13.287-012, Vinhedo/SP, Brazil
+55 97503 9323
contato@ringspann.com • www.ringspann.com.br

Chile, Peru, Colombia, Ecuador

RINGSPANN Sudamérica SpA

Isidora Goyenechea 3365, Piso 11, 8320000
Las Condes, Santiago-Región Metropolitana,
Chile • +56 9 9147 2833
info@ringspannsudamerica.com
www.ringspannsudamerica.com

USA, Canada, Mexico

RINGSPANN Corporation

10550 Anderson Place, Franklin Park, IL 60131, USA
+1 847 678 35 81
info@ringspann.us
www.ringspanncorp.com

Africa and Middle East

Egypt

Shofree Trading Co.

218 Emtedad Ramsis 2, 2775 Nasr City, Cairo, Egypt
+20 2 2081 2057
info@shofree.com • www.ringspann.com

Maghreb, West Africa

RINGSPANN France S.A.

23 rue Saint-Simon, 69009 Lyon, France
+33 4 7883 5901
info@ringspann.fr • www.ringspann.fr

Israel

Getter Group GG Yarom

4 Boltimor St., Petah Tikva, 4951015, Israel
+972 3 557 01 15
noam_a@gg.co.il • www.ringspann.com

South Africa, Sub-Saharan

RINGSPANN South Africa (Pty) Ltd.

96 Plane Road Spartan, Kempton Park,
P.O. Box 8111, Edenglen 1613, South Africa
+27 11 394 1830
info@ringspann.co.za • www.ringspann.co.za