

Brake Calipers EV 028 EFM and EH 028 EFM

electromagnetically activated – spring released



Features	Code
Brake Caliper with electromagnet	E
Mounting to the machine parallel or at right angles to the brake disc	V H
Frame size 028	028
Electromagnetically activated	E
Spring released	F
Manual adjustment to accommodate friction block wear	M
Supply voltage 220 to 240 VAC	240
Supply voltage 380 to 480 VAC	480
Electromagnet mounted in central position	M
Thickness of brake disc 10 ... 16 mm	12
or 18 ... 26 mm	25

Example for ordering

Brake Caliper EV 028 EFM, supply voltage 400 VAC, electromagnet mounted in central position, thickness of brake disc 15 mm:

EV 028 EFM - 480 M - 12

Advantages

The brake caliper EV 028 EFM or EH 028 EFM is a very compact and high efficient disc brake with very low power consumption. Its floating bearing compensates small misalignments of the brake disc. The attached electronic reduces the power consumption in closed position automatically.

Options

- Available with cCSAus approval
- Inductive proximity switch: "Brake released"-, "Brake closed"-status and/or "Friction block wear adjustment necessary"

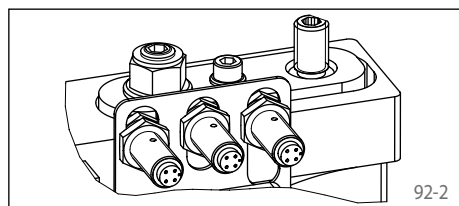

Technical Data

	Brake Calipers EV 028 EFM and EH 028 EFM with supply voltage	
	220 to 240 VAC	380 to 480 VAC
Brake disc diameter		
mm		
	Braking torque	Braking torque
	Nm	Nm
300	1170	
355	1450	
430	1820	
520	2270	
630	2820	
710	3220	
Clamping force	12500 N	
Response time*	250 ms	
Clamping force or braking torque adjustable	70 - 100%	
Power consumption in closed position	15 W	19 W
	(100% duty factor)	
Power when closing the brake (< 1 s)	1850 W	2500 W
Fuse rating	10 A, Type "B"	
Max. number of actuation	360/h permanent activations at 20° C ambient temperature	
Actuation frequency**	at least 8 seconds between 2 activations	
Weight	24 kg	

The braking torques shown in the diagram are based on a theoretical friction coefficient of 0,4.

* The response time is the duration from switching off the power supply to reaching 80% of the maximum clamping force (at Ta = 20 °C, setting: 100%).

** Shorter actuation frequency on request

Brake Calipers EV 028 EFM and EH 028 EFM

electromagnetically activated – spring released

Brake Caliper EV 028 EFM

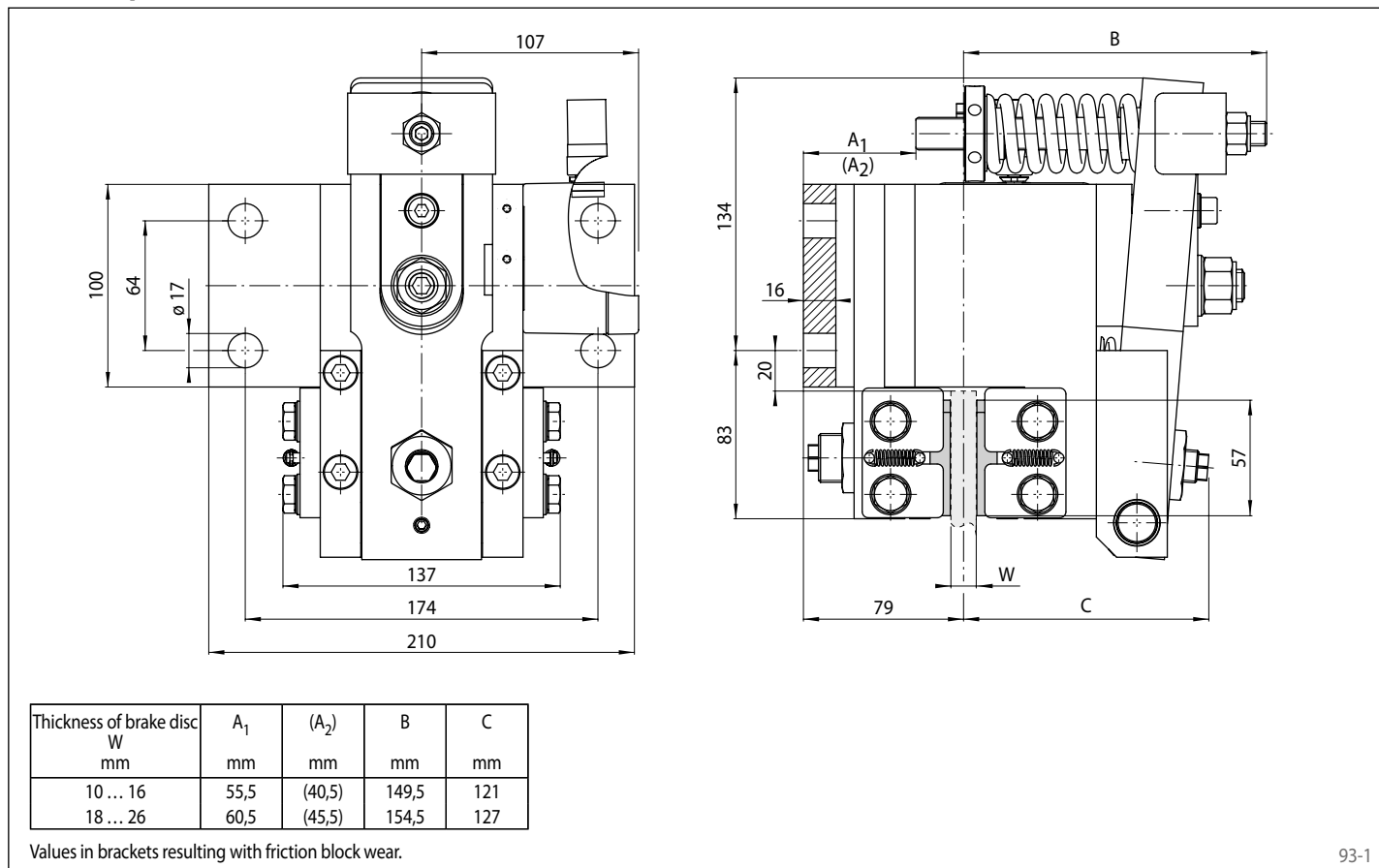

93-1

Brake Caliper EH 028 EFM

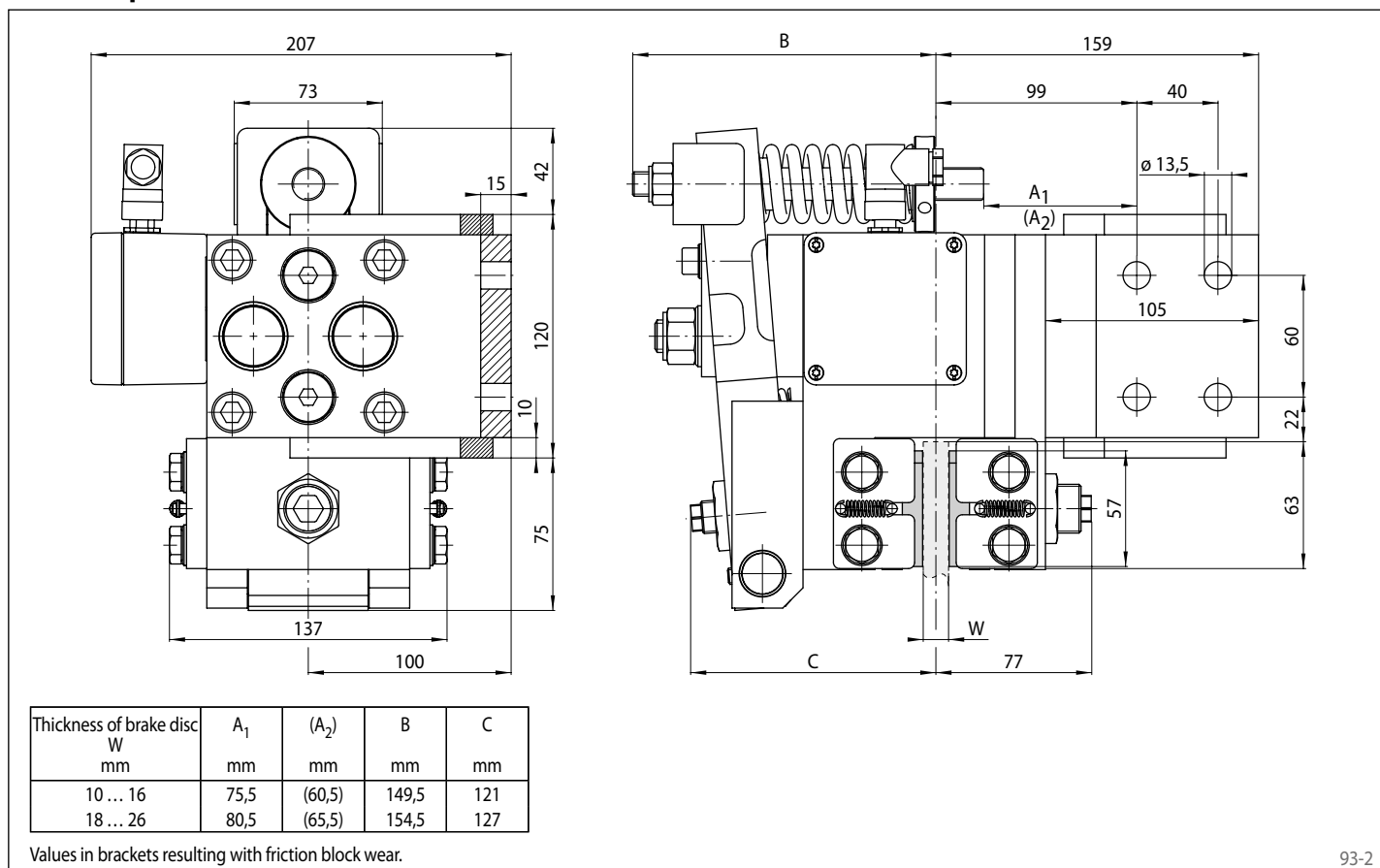

93-2