

Brake Caliper MV 044 FEM

spring activated – electromagnetically released



Features	Code
Brake Caliper with electromagnet	M
Mounting on the machine parallel to the brake disc	V
Frame size 044	044
Spring activated	F
Electromagnetically released	E
Manual adjustment to accommodate friction block wear	M
Supply voltage 380 to 480 VAC	480
Electromagnet mounted in central position	M
Thickness of brake disc 25 mm or 30 mm	25 30

Example for ordering

Brake Caliper MV 044 FEM, supply voltage 400 VAC, electromagnet mounted in central position, thickness of brake disc 25 mm:

MV 044 FEM - 480 M - 25

Advantages

The brake caliper MV 044 FEM is a very compact and high efficient disc brake with very low power consumption. Its floating bearing compensates small misalignments of the brake disc. The enclosed and robust design enables use in difficult ambient conditions with frequent braking operations. The attached electronic reduces the power consumption in open position automatically.

Options

- Inductive proximity switch: “Brake released”-status and/or “Friction block wear adjustment necessary”
- Lever for manual and controlled opening of the brake
- Mounting compensation shims up to approx. 2 mm

Technical Data

Brake Caliper MV 044 FEM with supply voltage 380 to 480 VAC	
Brake disc diameter	Braking torque
mm	Nm
355	2800
430	3600
520	4500
630	5600
710	6400
900	8300
Clamping force	25000 N
Response time*	150 ms
Power consumption in open position	30 W
Power when opening the brake (<0,2 s)	2200 W
Max. number of actuation	360/h
Actuation frequency**	at least 8 seconds between 2 activations
Weight	45 kg

The braking torques shown in the diagram are based on a theoretical friction coefficient of 0,4.

* The response time is the duration from switching off the power supply to reaching 80% of the maximum clamping force (at Ta = 20 °C).

** Shorter actuation frequency on request

Brake Caliper MV 044 FEM

spring activated – electromagnetically released

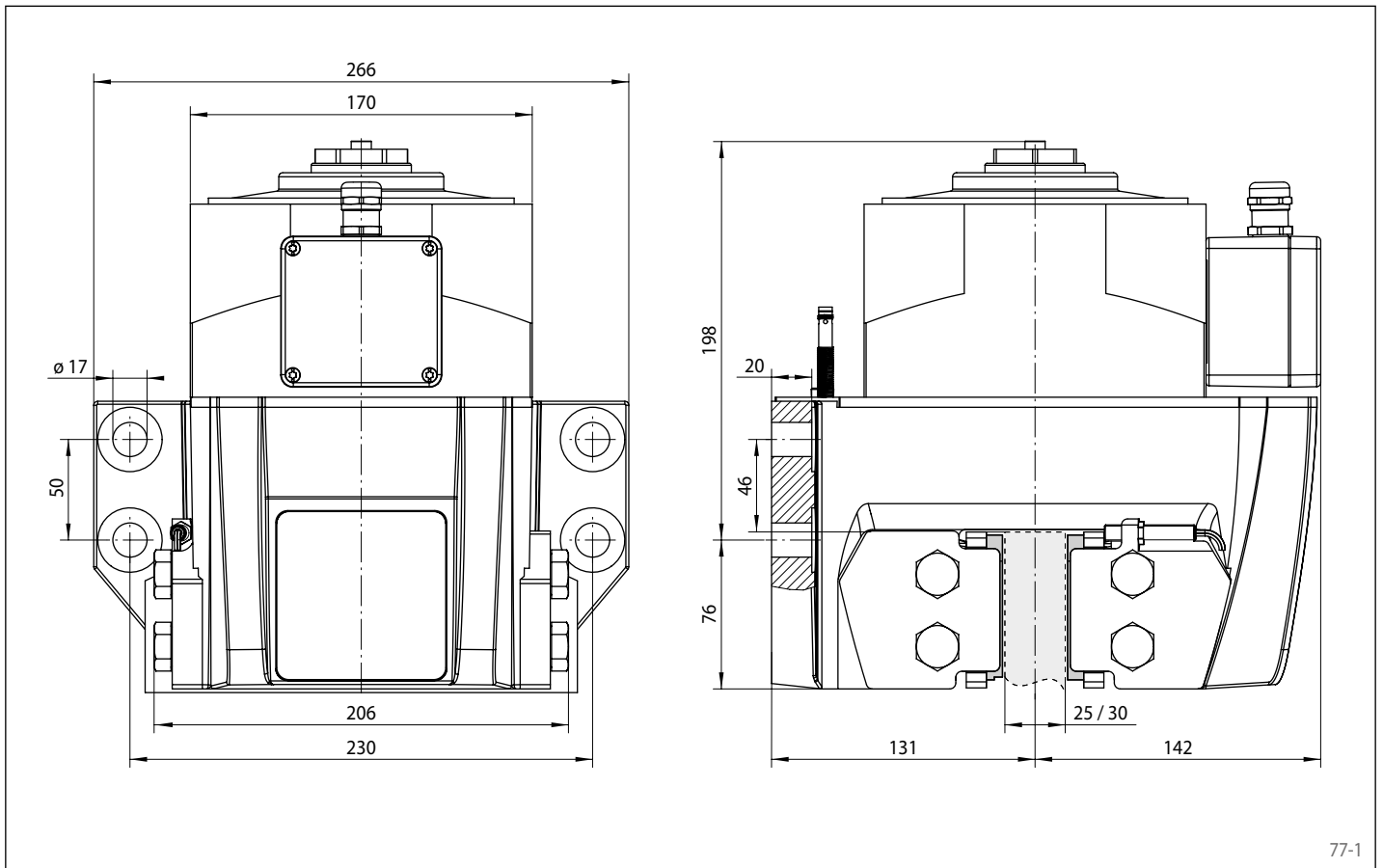

77-1