

**Installation and operating instructions for  
Brake disc with clamping element RLK 608**

**E 09.683**



**RINGSPANN GmbH**

Schaberweg 30-38  
61348 Bad Homburg  
Deutschland

Telefon +49 6172 275 0  
Telefax +49 6172 275 275

[www.ringspann.com](http://www.ringspann.com)  
[info@ringspann.com](mailto:info@ringspann.com)

<b>RINGSPANN</b>	<b>Installation and operating instructions for Brake disc with clamping element RLK 608</b>	<b>E 09.683</b>			
Issue: 13.04.2026	Version: 6	Drawn: BAHS	Checked: EISF	Pages: 5	Page: 2

---

## IMPORTANT

**Please read these instructions carefully before installing and operating the product. Your particular attention is drawn to the notes on safety.**

**These installation and operating instructions are valid on condition that the product meets the selection criteria for its proper use. Selection and design of the product is not the subject of these installation and operating instructions.**

**Disregarding or misinterpreting these installation and operating instructions invalidates any product liability or guarantee by RINGSPANN; the same applies if the product is taken apart or changed.**

**These installation and operating instructions should be kept in a safe place and should accompany the product if it is passed on to others - either on its own or as part of a machine- to make it accessible to the user.**

---

## SAFETY NOTICE

- Installation and operation of this product should only be carried out by skilled personnel.
- Repairs may only be carried out by the manufacturer or accredited RINGSPANN agents.
- If a malfunction is indicated, the product or the machine into which it is installed, should be stopped immediately and either RINGSPANN or an accredited RINGSPANN agent should be informed.
- Switch off the power supply before commencing work on electrical components.
- Rotating machine elements must be protected by the purchaser to prevent accidental contact.
- Supplies abroad are subject to the safety laws prevailing in those countries.

**This is a translation of the German original version!**

In case of inconsistencies between the German and English version of this installation and operating instruction, the German version shall prevail.

<b>RINGSPANN</b>	<b>Installation and operating instructions for Brake disc with clamping element RLK 608</b>	<b>E 09.683</b>			
Issue: 13.04.2026	Version: 6	Drawn: BAHS	Checked: EISF	Pages: 5	Page: 3

## General information

A brake disc is mounted friction-tight to a shaft using components of the RLK 608 cone clamping element.

The complete unit consists of:

- one brake disc
- one tapered step ring
- one tapered step bushing
- and clamping screws

The brake disc is made of cast iron with spheroid graphite (sphero-cast), material designation GGG-50 as defined in DIN 1693, or DIN EN 1563, Material no. 0.7050. The maximum permissible circumferential speed is 96 m/s. The resulting maximum permissible rpm values are listed in the table in the "Technical data" section. **The brake disc may not be operated at higher speeds under any circumstances due to the danger of explosion under the influence of centrifugal force.**

The prescribed shaft tolerance is quality h6. The average peak-to-valley height of the shaft should be  $R_z \leq 15 \mu\text{m}$ .

When the unit is configured for maximum permissible braking force, a friction value of  $\mu = 0,15$ , pairing steel/steel, is used as a base value.

The unit is preassembled and packed in rust-inhibiting paper for delivery.

## Configuration and parts designations

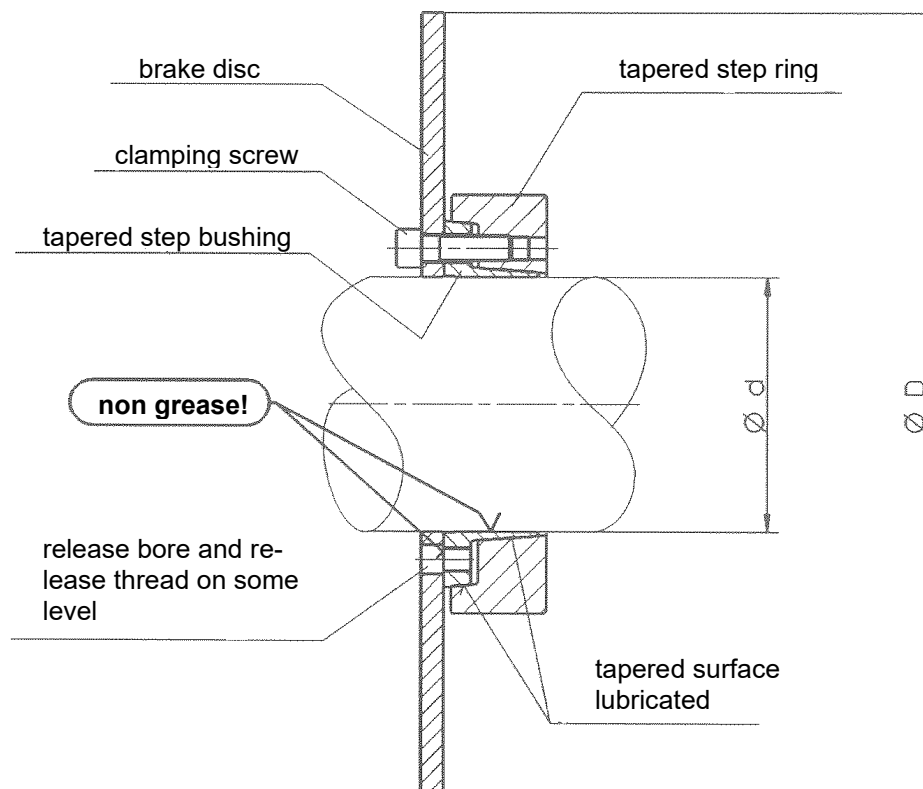

<b>RINGSPANN</b>	<b>Installation and operating instructions for Brake disc with clamping element RLK 608</b>			<b>E 09.683</b>	
Issue: 13.04.2026	Version: 6	Drawn: BAHS	Checked: EISF	Pages: 5	Page: 4

## **Installation**

Degrease the shaft and the bore in the tapered step bushing.

Ensure that all screws are loosened and the tapered step bushing is loosely inserted into the tapered step ring.

Slide the complete unit onto the shaft.

Tighten the clamping screws by hand, proceeding in a crosswise sequence. Position the unit so that the brake disc is aligned on a parallel plane parallel to the tapered step ring. Then tighten the clamping screws one by one, turning each screw a maximum of 60° in each step with a torque wrench set to the prescribed torque until all screws are properly tightened. The tightening procedure is complete only when no clamping screw can be turned any further. The prescribed torque value is listed in the "Technical data " section.

Check brake disc wobble. Maximum permissible wobble is 0.2 mm. A greater degree of wobble can cause chatter and shaking in the brake unit.

## **Dismantling**

Loosen the clamping screws one by one in multiple steps to ensure that the clamping surface does not jam.

The clamping screws must not be completely removed from the threaded bores, as this could increase the risk of accidents.

Do not loosen the tapered step ring and the tapered step bushing. Remove a number of screws equivalent to the number of threaded clamping bores and turn the screws into the clamping bores uniformly until the tapered step bushing is pressed out of the tapered step ring.

Remove the complete unit from the shaft.

## **Lubrication**

The tapered surfaces are coated with an MoS<sub>2</sub> –based glide lacquer.

Disassemble and clean the dismantled unit before replacing it on the shaft. Then lubricate the tapered surfaces with Molykote BR2.

Tapered step rings and step bushings with damaged tapered surfaces must be replaced.

### Technical data

Shaft-Ø d (mm)	Brake disc out- side -Ø D (mm)	Maximum per- missible speed (min <sup>-1</sup> )	Clamping screws	Tightening torque*) (Nm)	Maximum Bra- king torque (Nm)
36	150	12.100	M 8x30 DIN 912-8.8	24	150
30	200	9.100	M 6x35 DIN 912-8.8	10,1	80
50	250	7.300	M 8x35 DIN 912-8.8	24	322
80	300	6.000	M 10x35 DIN 912-8.8	48	950
90	300	6.000	M 10x35 DIN 912-8.8	48	1050
80	355	5.100	M 10x35 DIN 912-8.8	48	950
140	400	4.500	M 14x50 DIN 912-8.8	133	3750
90	430	4.200	M 10x40 DIN 912-10.9	71	1500
110	430	4.200	M 12x50 DIN 912-8.8	84	2000
160	520	3.500	M 16x55 DIN 912-8.8	206	6000
200	520	3.500	M 16x55 DIN 912-8.8	206	9500
280	630	2.900	M 20x90 DIN 912-8.8	592	30000

\*)calculated with  $\mu_G$  and  $\mu_K= 0.12$  as a mean friction coefficient (in accordance with VDI Guideline 2230, Version 2001)